

Alert Service Bulletin No 33



1. General

(a) No.:	33
(b) Revision / Date	0 / 04 May 2022
(c) Title:	ALUGAS Cylinders - Temporary withdrawal from service
(d) Description:	Temporary withdrawal from service of CB2990 (Alugas) cylinders
(e) Applicability:	All hot-air balloons (from all manufacturers) fitted with CB2990 (Alugas) cylinders
(f) Effectivity:	Fuel cylinders Part Number CB2990 (Alugas) cylinders having serial numbers: OC25001 to OC25202 QI14001 to QI14494 Note: This serial number range covers all CB2990 (Alugas) cylinders currently in service. These fuel cylinders are known to be installed on, but not limited to, hot-air balloons and airships manufactured by Cameron Balloons Ltd, Colt Balloons, Lindstrand Balloons Ltd (LBL), Lindstrand Hot Air Balloons Ltd, Sky Balloons, Thunder Balloons, and Thunder & Colt

Note: Applicability= All types and variants to which the change can be applied.
Effectivity= Actual CN or group of CN's to which the bulletin has been/will be applied.

2. Background

Five CB2990 (Alugas) cylinders have developed cracks in the weld between the cylinder valve plate and the upper dished end. These cracks allow the release of propane from the cylinder. Failures have been observed during periodic inspection (hydraulic pressure test), and leak test. All the in-service failures seen to date have been from the batch of cylinders with serial numbers starting OC.

It is likely that other CB2990 cylinders may develop similar failures in service.

To address this potential unsafe condition this service bulletin is issued to temporarily withdraw all CB2990 (Alugas) cylinders from service pending investigation of these failures.

Cameron Balloons are working urgently with the original fabricator to determine the cause and scope of these failures.

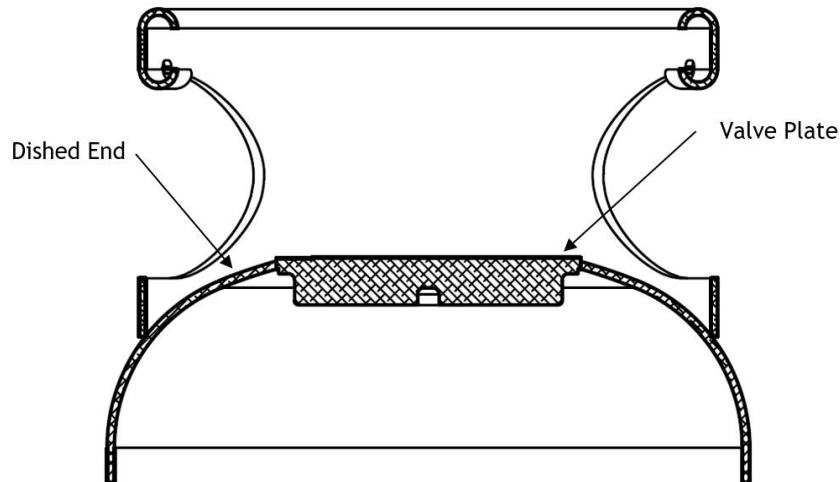

Figure 1 - Section indicating Valve Plate

3. Compliance (Category)

Required on receipt of this bulletin.

4. Consequences of Non-Compliance (Possible)

Uncontrolled leak of LPG fuel.

5. Accomplishment Instructions

Affected Cylinders are prohibited from further flight.

Within 24 hours of receipt of this bulletin affected cylinders must be checked for leaking around the interface between the cylinder valve plate and the upper dished end using leak detector fluid. Any cylinders found to be leaking must be emptied of fuel immediately. A pilot may carry out this inspection. A satisfactory leak check **does not** release the cylinder to service.

Within 7 days of receipt of this bulletin affected cylinders must be emptied of fuel.

6. Materials: None

7. Other Publications Affected: None

8. Mass (Weight)/Balance: Not Affected

9. Maintenance and Operating Instructions: Not Affected

10. Additional Information

For any questions concerning the technical content of the requirements in this Service Bulletin, please contact:

Cameron Balloons Limited
St Johns Street Bedminster Bristol, UK
BS3 4NH
Email: technical@cameronballoons.co.uk
tel: +44 (0)117 9637216

Compiled by:



Notes:

Date: 4/5/22 Name: D J Cameron

11. Design Organisation Approval

Statement of Compliance Verification

I hereby confirm that the instructions identified in this bulletin provide for practical and well-defined installation/inspection methods and when accomplished the product is in conformance with approved design data.

Signed, for and on behalf of Cameron Balloons Ltd.



Head of Airworthiness

Date: 4-5-22 Name: D C Boxall

Approval Statement

I hereby confirm that these instructions are in compliance with all the applicable airworthiness requirements. The technical content of this document is approved under the authority of DOA nr UK.21J.0140

Signed, for and on behalf of Cameron Balloons Ltd.



Head of Design



Date: 4-5-22 Name: D. A. CAMERON

Note: If this Service Bulletin is or will become an Airworthiness Directive, a statement to that effect must be entered in Section 10 of this form.