

The technical content of this document is approved under the authority of DOA ref. nr. UK.21J.0140 (Mod C927)

7.52 PERIODIC INSPECTION OF FUEL CYLINDERS

WARNING: With cylinders used for the storage of LPG there is a great danger that residual gas mixed with air will cause a fire or explosion hazard. The cylinder must be emptied and depressurised in a safe manner, then purged with nitrogen (N₂) or other non-oxidising gas prior to any internal inspection or maintenance.

WARNING: There is a risk of fuel being retained in cylinder contents gauge floats, especially if the gauge has failed. The pressure of the retained fuel may cause failure of the float, releasing plastic fragments. Appropriate PPE should be worn (including eye protection and gloves). Removed contents gauges should be stored safely.

WARNING: Contents gauges on CB2990 (Alugas) cylinders must be installed by hand. Use of an impact wrench is not permitted.

7.52.1 GENERAL

Issue 8 of this supplement has 14 pages.

This supplement calls for the use of substances and procedures that may be injurious to health if adequate precautions are not taken. It refers only to technical suitability and does not absolve the user from legal obligations relating to health and safety at any stage. It has been assumed in the drafting of this supplement that the execution of its provisions is entrusted to appropriately qualified and experienced people. Where judgements are called for, it has been assumed that they are made by competent persons who have been trained specifically for the task. In cases of doubt contact Cameron Balloons Limited. This supplement has been drafted to address both terrestrial transportation and airworthiness criteria.

The periodic inspection is required 10 years from the initial test date of the cylinder and every 10 years subsequent. The procedures for periodic inspection consist of:-

- External Visual Inspection
- Internal Visual inspection
- Hydraulic Proof Pressure test
- Pneumatic leak test

The decision to render the cylinder unserviceable may be taken at any stage in the inspection procedure. With the agreement of the owner the cylinder shall be rendered unserviceable, refer to Section 7.52.9.

NOTE: If any unacceptable defects are found during the external or internal inspections the cylinder must be rejected. A satisfactory proof pressure test does not allow other defects to be ignored.

7.52.1.1 Scope

This supplement is applicable to the following cylinders:-

Cylinder Material	Part Number
Aluminium	Cameron:CB250: Worthington DOT-4E-240 Cylinder, CB901: Worthington DOT-4E-260 6lb Vapour Cylinder, CB2990: Alugas 50l Cylinder. Colt (including Thunder & Colt): Worthington Lindstrand: Worthington (CY-010-A-001), Worthington, Hopper (CY-011-A-001)
Austenitic Stainless Steel	Cameron: CB426, CB497, CB599, CB959, CB2088. Colt (including Thunder & Colt): V20 (V20-1000), V30 (830922-1, CB8430), V40(V40-100,CB8440), H30 (SC2-106, AS82-310, 830201, CB8424, CB9413), H40 (AS82-410, SC2-106, CB8414, CB9412), H55 (880507-1,H55-300). Lindstrand: V20 (CY-020-A-001), V30 (CY-030-A-001), V30-Hopper (CY-031-A-001),V40 (CY-040-A-001). SKY: V30, V40
Titanium	Cameron: CB2380, CB2383, CB2385, CB2387. Lindstrand: T30 (CY-050-A-001).
Duplex Stainless Steel	Cameron: CB2900, CB2901, CB2902, CB2903

NOTE: Duplex stainless steel cylinders were also supplied with Lindstrand branding but can be regarded as identical to Cameron cylinders of the same part number.

7.52.1.2 Pressure Relief Valves

Pressure relief valves (PRVs) must be replaced as part of the periodic inspection. PRVs have a permitted shelf life of five years and a projected service life (subject to inspection) of ten years. At the time of installation pressure relief valves must have sufficient life remaining to reach the date of next intended periodic inspection. PRV replacement is part of the periodic inspection and not a separate maintenance action.

Where the PRV is integral with the valve the complete valve should be replaced.

7.52.2 EXTERNAL VISUAL INSPECTION

Remove the cylinder jacket and protective foam. For Lindstrand T30 cylinders the upper and lower guard rings must also be removed.

If required, the cylinder shall be cleaned to remove corrosion products or other foreign matter from its surface.

WARNING: Stainless Steel Cylinders should only be cleaned with products designed for cleaning Austenitic Stainless Steels. Abrasive Pads, wire brushes etc. used for cleaning must be stored and labelled to only be used on a single material. e.g. pads used for cleaning stainless steel cylinders shall not be used for cleaning Titanium cylinders and vice versa.

The entire external surface of the cylinder shall be inspected for:-

- a. Dents, cuts, gouges, bulges, cracks and punctures applying the criteria for rejection in the Maintenance Manual (Section 6).

- b. Corrosion giving special attention to areas where water can be trapped, to the base of the cylinder, to the joints between the pressure vessel and the upper and lower guard plates and to the longitudinal and circumferential welds.
- c. Integrity of permanent attachments, including the cylinder data plate.
- d. Any other defects.

7.52.3 INTERNAL VISUAL INSPECTION

7.52.3.1 Preparation

Cylinders shall be depressurised in a safe and controlled manner before proceeding.

Cylinder valves and fitting shall be removed for inspection, maintenance, refurbishment or scrapping in accordance with EN 14912 or national requirements.

7.52.3.2 Cleaning

The cylinder may be cleaned internally by adding a small quantity of kerosene and swilling it around the cylinder, or with a commercially available water-based degreasing agent. The cleaning process can be assisted by a high pressure water or steam jet. Repeat the process as necessary. Care should be taken not to damage the cylinder walls.

WARNING: Alcohol or commercial alcohol based cleaners must never be used to clean or dry titanium cylinders.

7.52.3.3 Inspection

After removing the residual liquid, and any other foreign matter from the interior, cylinders shall be inspected internally for any sign of corrosion or other defects that may affect their integrity, using a safe inspection lighting system with appropriate internal illumination (e.g. an endoscope).

Cylinders showing signs of internal corrosion, except those having only a thin layer of surface rust (stainless steel and Duplex stainless steel only) shall be removed for further detailed examination.

If further cleaning is required care shall be taken to avoid damaging the cylinder walls. Cylinders shall be re-inspected after cleaning.

7.52.3.4 Inspection of Cylinder Threads

The internal threads of the cylinder shall be visually examined to ensure that they are full form and clean. They shall be examined for burrs, cracks and other thread damage.

7.52.4 Hydraulic Proof Pressure Test

7.52.4.1 General

WARNING: Liquids that have been used for testing carbon steel cylinders should not be used for testing cylinders made of aluminium, stainless steel or titanium to prevent ferritic contamination.

A liquid shall be used as the test medium, e.g. water or kerosene. Water for testing the cylinders shall be potable quality with a chloride ion content of less than 50 ppm.

The test pressure (Ph or Pt) for all cylinders is 3.0 Mpa (30 Bar).

NOTE: Older cylinders have a test pressure of 3.3 Mpa engraved on the data plate. These cylinders should be tested to 3.0 Mpa and the data plate amended (if required).

7.52.4.2 Preparation

In addition to the requirements of 7.52.3.1, the external surface of the cylinder shall be in such condition that any leak can be detected. If the cleaning method involves wetting the outside surface, the outside surface shall be completely dried before commencing the test procedure.

All cylinder ports other than those required for filling or pressure measurement during the test procedure shall be sealed using suitable blanks.

7.52.4.3 Test Equipment

Testing should be carried out using the CB2882 test kit, or equivalent equipment.

The design and installation of the equipment and the cylinders connected to it shall ensure that no air is trapped in the system.

All joints within the system shall be leak tight.

A device shall be fitted to the test equipment to ensure that no cylinder is subjected to pressure in excess of its test pressure by 0.2 Mpa (2 Bar).

Pressure gauges that are used to read the cylinder test pressure shall be in accordance with EN 837-1:1996 and EN 837-3:1996, accuracy class 1,6 or better (alternative standards giving the same level of accuracy can be used). They shall be calibrated or checked for accuracy against a master gauge at regular intervals and not less frequently than once every six months. The master gauge shall be re-calibrated in accordance with national requirements.

The test equipment shall not restrict the expansion of the cylinder.

7.52.4.4 Procedure

More than one cylinder may be tested at a time provided they all have a test pressure within the tolerance specified.

Cylinders shall be depressurized in a safe and controlled manner before proceeding.

The cylinder shall be positioned so that the welds are visible during the test.

The pressure shall be increased gradually until the test pressure is reached.

The test pressure shall be held for the time necessary to inspect the cylinder and examine it for any leak and/or other defects, but not less than 5 minutes.

If there is leakage in the pressure test system, it shall be corrected and the cylinders retested.

Cylinders that do not leak or show any visible permanent distortion after the pressure test shall be deemed to have passed this test.

Cylinders that fail this test shall be rejected. Records of rejected cylinders shall be maintained.

After testing the cylinder should be drained and thoroughly dried and precautions taken to prevent internal corrosion. Standing water should not be allowed to evaporate to dryness, unless de-ionized water is used as a final rinse.

7.52.5 VALVES AND FITTINGS

7.52.5.1 General

New, inspected or refurbished valves approved by the manufacturer shall be fitted (Section 7.52.10). It is recommended that the liquid valve sealing rings (REGO style liquid valves), contents gauge seal and retaining screws are replaced.

7.52.5.2 Fixed Liquid Level Gauge

If the Fixed Liquid Level Gauge (FLLG) is to be refitted, the length shall be checked in accordance with the dimensions given in Figure 7.52.1.

Check that the bleed screw 'A' is captive and that the length 'B' is correct for the cylinder. If not, the FLLG must be replaced.

These lengths give an approximate 80% fill when filling by volume.

NOTE: If a cylinder type is not listed, contact Cameron Balloons Limited.

NOTE: Sky Balloons V30 and V40 cylinders have integral dip tubes, therefore the FLLG valve does not have a dip tube fitted.

NOTE: For the CB901 Cylinder type the FLLG is integral with the CB981 off-take valve.

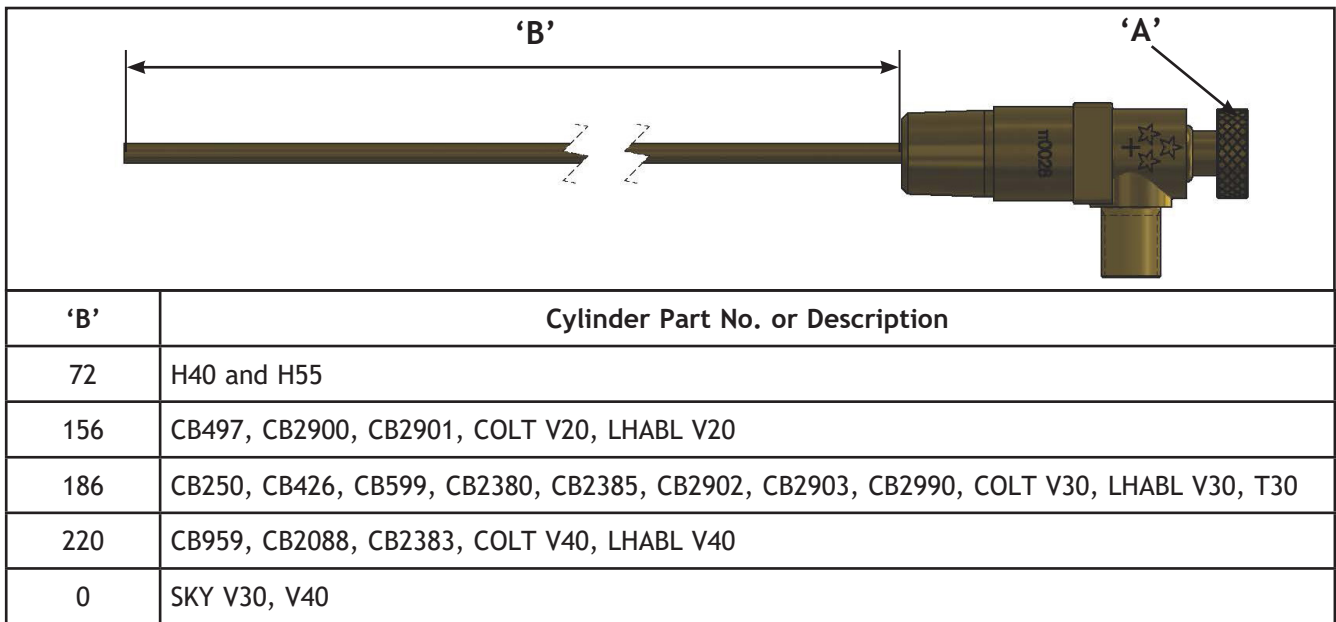

▲ Fig 7.52.1 FLLG Details

7.52.5.3 Assembly

Contents gauge screws shall be assembled with a low to medium strength thread locking compound e.g. Loctite 222 or 243.

When testing several cylinders at the same time take great care that the correct contents gauge screws are re-installed into each cylinder. M6 and 1/4" UNF screws have a similar appearance. If in doubt check the thread pitch with a thread gauge. M6 screws have a 1 mm thread pitch, 1/4" UNF screws have 28 threads per inch. The material type may be checked with a magnet. Zinc plated Steel screws are strongly magnetic. Stainless Steel screws are either non-magnetic or weakly magnetic. A variety of head shapes have been used in the past and head shape is not a reliable indicator of screw type.

Valves should be assembled with two to three layers of PTFE tape and PTFE paste in accordance with Section 4 of the Maintenance Manual.

NOTE: Where valves are supplied with a pre-applied sealant, e.g. Everseal 183, no additional sealant is required.

Torque tightening values are given in Table 7.52.2 but for tapered threads (NPT or NGT) the following alternative method is recommended due to the variations involved such as dissimilar materials of male and female threads, type of sealants used etc. If torque wrenches are used, the thread engagement must be checked in accordance with Table 7.52.1.

7.52.5.4 Assembly - Taper Threads

The threads in the valve bosses of the cylinder are 1/4NPT and 3/4NPT (National Pipe Thread) which are tapered threads. Because of the taper, an NPT thread can only screw into a fitting a certain distance before it jams.

Tapered threads shall be assembled with PTFE Tape and paste. Refer to Maintenance Manual Section 4.2.2.

The NPT standard specifies the length of hand tight engagement (the distance the pipe thread can be screwed in by hand) and the effective thread (the length of the thread which makes the seal). In practical terms these distances can be translated into how many turns to make by hand and how many with a spanner.

A simple method of installing these valves is to screw the valve into the boss until it is hand tight and then tighten with a spanner for an additional 1-2 turns.

Table 7.52.1 shows the distances and number of turns called for in the standard. A tolerance of plus or minus one turn is allowed.

CAUTION: Only use flat jaw spanners. Stilsons/pipe wrenches must not be used.

Table 7.52.1 Taper Thread dimensions

Nominal Size	Actual OD in (mm)	Threads per Inch	Length of engagement (tighten by hand) in (mm)	Length of effective thread in (mm)
1/4"	0.546 (13.87)	18	0.172 (4.37)=3.1turns	0.401(10.19)
3/4"	0.681 (17.3)	14	0.267(6.78)=3.7 turns	0.546 (13.87)

Table 7.52.2 Torque Tightening Values

Fitting	Thread Form	Torque (Nm)
Fixed Liquid Level Gauge (FLLG)	1/4"NPT	28-50
Liquid Offtake	3/4"NPT	110-200
Vapour Offtake	3/4"NPT	110-200
Blanking Plug	3/4"NPT	110-200
Pressure Relief Valve	3/4"NPT	110-200
Overfill Protection Device (OPD)	3/4"NPT	90-130
QSO Flanged Adaptor CB437	3/4"NPT	110-200
QSO Flanged Adaptor CB2945	3/4"NPT	80 - 130
Threaded Contents Gauge	3/4"NPT	70 - 130
Contents Gauge Screws	M6	3-5
Contents Gauge Screws	1/4"UNF	3-5
QSO retaining Bolts	M6	3-5
QSO Outlet	7/8"UNF	50
QSO Outlet	3/8"BSP	50
Vapour Regulator	3/4"NPT	50-80
Vapour Regulator Quick Coupling	1/4" BSPT	4-6

NOTE: 1 Nm = 0.737 lb ft = 8.85 lb in.

7.52.5.5 Padded Cover

The main body of Stainless Steel, Duplex Stainless Steel and Titanium cylinders shall be covered by an outer, water-resistant protective layer at least 25mm thick made from

structural cellular foam or similar material. However, a thin foam alternative may be used but only with cylinders manufactured in accordance to EN14140 as indicated on the dataplate

The thin foam alternative adopts a closed cell 10mm high density foam approved by Cameron Balloons LTD and detailed in the Flight Manual Supplement 8.63.

7.52.5.6 PRV Adaptor: CB8426

Colt, Lindstrand, and Sky cylinders were originally fitted with a Sherwood PV435L pressure relief valve. This valve may be replaced with the Omeca 660248 valve (CB8412-1000) by fitting an adaptor, CB8426, into the cylinder boss before fitting the valve.

NOTE: It is recommended that when installing a PRV adapter into the cylinder boss and a PRV into the PRV adapter both the adapter and PRV are fitted in accordance with the method detailed in 7.52.5.4.

7.52.6 PNEUMATIC LEAK TEST

1. Close all valves.
2. Charge the cylinder, through the liquid valve, with the pneumatic test medium (e.g. dried compressed air, nitrogen). The minimum pressure in the cylinder should be 0.6 Mpa (6 bar).
3. Isolate the cylinder from the supply.
4. Perform a leak check as detailed in the annual inspection procedure.
5. Vent cylinder to atmospheric pressure.

Cylinders that do not leak shall be deemed to have passed this test.

WARNING: Always vent the cylinder after testing.

7.52.7 TARE WEIGHT

The tare weight or indication of the tare weight shall be re-established if any modification or re-valving has been made which affects the tare weight of the cylinder.

If the new tare indication is different from the old tare indication, it shall be marked on the cylinder and the former tare shall be made unreadable.

7.52.8 MARKING

After successful completion of the periodic inspection, each cylinder shall be legibly and durably marked in accordance with EN14894 or national regulations.

As a minimum the cylinder shall be marked with:

- a. the symbol of the re-qualification test station or the symbol of an inspection body.
- b. the year and month of the re-qualification.
- c. the date of the next re-qualification.

The markings shall be not less than 4 mm in height.

WARNING: The cylinder must only be marked on either the guard ring or foot ring. The cylinder must not be marked on the pressure vessel.

7.52.8 PURGING

Air shall be removed from the cylinder, e.g. by evacuation or by displacement with LPG.

NOTE: This may be done at the test station or during filling.

7.52.9 FAILED CYLINDERS

NOTE: If a cylinder has been deemed unsuitable for further service, it is deemed unsuitable for use in aircraft AND unsuitable for the safe storage liquefied gases.

The rejected cylinder must be rendered unserviceable in accordance with EN 12816 or applicable national regulations.

The serial number of a failed cylinder should be entered in the aircraft logbook.

7.52.10 REPLACEMENT PARTS

In addition to the items listed in the Maintenance Manual Section 8.4.3 the following replacement parts are available.

Where replacement parts are not listed, please contact Cameron Balloons Limited for further information.

7.52.10.1 Contents Gauge

Part No.	Description	Applicability
CB-2561-0000	Gasket, Contents Gauge	All cylinders
CB-2990-5000	Gasket, Contents Gauge	(alternative to CB2561-0000)
CB-2551-0000	Contents Gauge	CB497, Worthington (CB250), V20 (Colt, Lindstrand, Sky), LHABL T30
CB-2552-0000	Contents Gauge	V30 (Colt, Lindstrand, Sky) CB426, CB599, CB2380, CB2385, CB2900, CB2901
CB-2553-0000	Contents Gauge	V40 (Colt, Lindstrand, Sky) CB959, CB2088, CB2383, CB2387, CB2903
CY-5000-0014	Screw, 1/4"UNF x 7/8" (22mm) long. Zinc plated steel	CB426, CB497, CB599, CB959, CB2088, Worthington (CB250)
CY-5000-0013	Screw, 1/4"UNF x 7/8" (22mm) long. Stainless Steel.	CB2380, CB2383, CB2385, CB2387, CB2900, CB2901, CB2902, CB2903
CB7913-0000	7381 3/4" Gauge Assembly	CB2990
CB-7917-0000	Cylinder 60l Contents Gauge - Solid Float	CB2900, CB2901
CB-7918-0000	Cylinder 72l Contents Gauge - Solid Float	CB2902, CB2903

7.52.10.2 Fixed Liquid Level Gauge (FLLG)

Part No.	Description	Applicability
CB-2480-0021	FLLG -186 mm Dip Tube	Refer to Figure 7.52.1
CB-2480-0022	FLLG -220 mm Dip Tube	
CB-2480-0023	FLLG -156 mm Dip Tube	
CB-2480-0024	FLLG -0 mm Dip Tube	
CB-2483-0000	Blanking Nut (Outlet Thread)	All of the above

7.52.10.3 Pressure Relief Valve

Part No.	Description	Applicability
CB-8412-1000	Omeca 660248	CB250 (Worthington), CB426, CB497, CB599, CB959, CB2088, CB2380, CB2383, CB2385, CB2900, CB2901, CB2902, CB2903, CB2990, V20*, V30*, V40* (Colt, Lindstrand, Sky), LHABL T30
CA-0001-0171	Sherwood PV435L	V20, V30, V40 (Colt, Lindstrand, Sky)
CB-8412-2000	REGO8545AK	CB250 (Worthington), CB426, CB497, CB599, CB959, CB2088, CB2380, CB2383, CB2385, CB2900, CB2901, CB2902, CB2903, CB2990, LHABL T30
CB-8412-3000	Ceodeux 071131	
CB-8412-4000	Sherwood PV435A	
CB-8426-0000	PRV Adaptor	V20, V30, V40 (Colt, Lindstrand, Sky)
CB-0981-0000	Vapour Valve Incorporating PRV	CB901 (6 lb Vapour Cylinder)

7.52.10.4 Liquid Valve

7.52.10.4.1 Handwheel (REGO) Valve

Part No.	Description	Applicability
CB-2992-0000	Liquid valve with integral dip tube	CB2990
CB-7900-0000	Liquid valve, Hi-Flow	All cylinders except CB2990
CB-0824-0001	Liquid Valve, Handwheel (BMV344)	
CB-2628-0000	Self Seal Repair Kit (BMV344)	All cylinders
CT-8180-9000	Dust Cap	
CB-2629-0000	Main Seal Repair Kit	

7.52.10.4.2 Quick Shut Off (QSO) Valve

Part No.	Description	Applicability
CB-0671-3000	QSO Valve Assembly Tema Duplex	CB2900, CB2901, CB2902, CB2903
CB-0671-4000	QSO Valve Assembly Rego Duplex	
CB-0671-7000	QSO Valve Assembly Tema CB2990/B	CB2990
CB-0671-8000	QSO Valve Assembly Rego CB2990/B	CB2990
CB-0671-1000	Liquid Valve, QSO, 1¼"ACME Outlet	All cylinders not listed above
CB-0671-2000	Liquid Valve, QSO, TEMA 3800 Outlet	
CB-0392-0018	Seal Kit, QSO, (Worcester Type 44 Ball Valve)	All cylinders
CB-0671-0007	TEMA 3800 Outlet	
CH-3800-0003	Bonded Seal (3/8"BSP)	
CH-3800-0006	Dust Cap (TEMA 3825)	
CB-8407-0000	Outlet Adapter, 1¼"ACME	

7.52.10.5 Vapour Valve

Part No.	Description	Applicability
CB-2884-0000	Vapour Valve, 3/8 NPT outlet	CB426, CB497, CB599, CB959, CB2088
CB-2896-000 + CB-2895-0000	Vapour Valve, PRV 3/8 NPT outlet + dip tube	CB2830, CB2383, CB2385, CB2387 CB2900, CB2901, CB2902, CB2903
CB-2883-0000	Vapour Valve, PRV, POL Outlet	Lindstrand / T&C V20, V30 and V40, CB250, CB426, CB497, CB599, CB959, CB2088
CQ-2000-0001	Vapour Valve, PRV, POL Outlet & dip tube	CB2830, CB2383, CB2385, CB2387 CB2900, CB2901, CB2902, CB2903
CQ-2000-1000	Vapour regulator dynaquip. POL inlet.	All Cylinders
CQ-2000-2000	Vapour regulator Tema. POL inlet.	
CT-0250-0013	Blanking Plug, 3/4 NPT	
CB-0981-0000	Vapour Valve (Incorporating PRV and FFLG.)	CB901

7.52.10.6 COMPONENT ORIENTATION

7.52.10.6.1 Duplex Stainless Steel Cylinders

Correct orientation of the contents gauge is required to prevent a possible clash between the gauge float and the cylinder dip tube.

CB2552-0000 and CB2553-0000 (LIVELLO) gauges must be orientated with the 'TOP' label nearest the PRV. CB7917-0000 and CB7918-0000 (ROCHESTER) gauges must be orientated with the pointed part of the dial cover nearest the PRV. See fig. 7.52.2 for the correct orientation of both types.

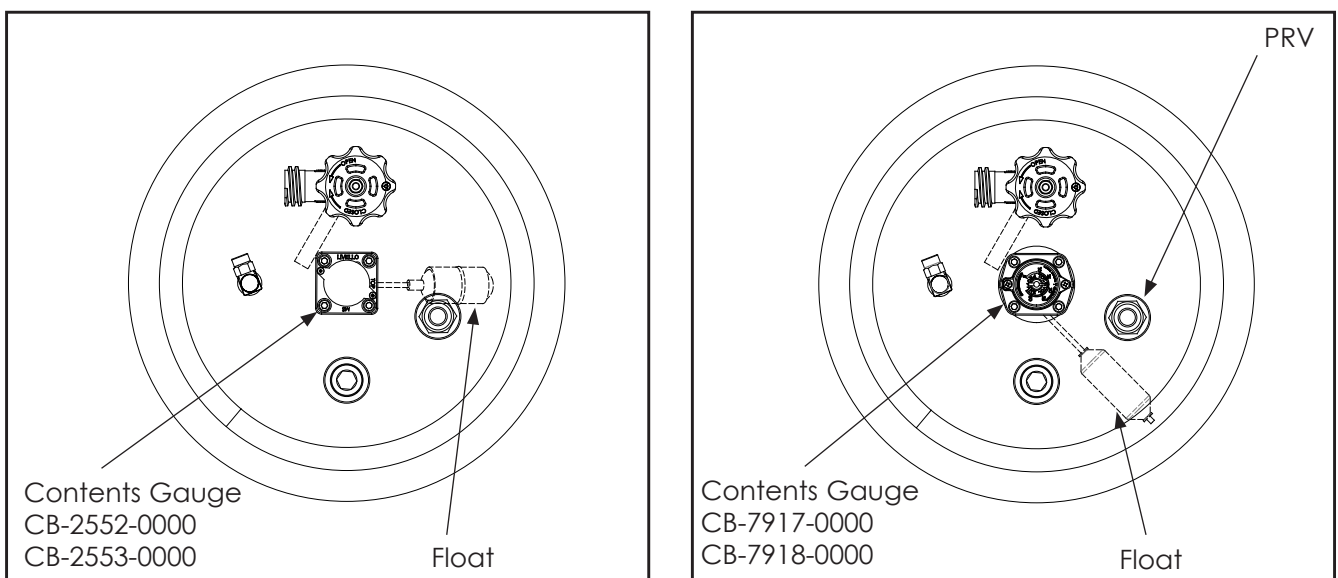

▲ Fig. 7.52.2: Orientation of Gauge

7.52.10.6.2 Alugas cylinders CB2990

Orientation and order of assembly of the cylinder components are important to avoid clashes between components. The following must be observed:

1. The Liquid Handwheel have must be installed before the Gauge and PRV.
2. the QSO Flanged Adaptor must be orientated to the PRV as shown. Ensure the QSO handle is clear of the Gauge when in the closed position.
3. The gauge body must be orientated to the cylinder orientation mark as shown.

WARNING: The gauge must not be installed with power tools that uses a hammer function. Installation by hand at low rotational speed is required. It is recommended that the gauge is installed last.

4. The FLLG should be installed to ensure it's outlet does not clash with the guard ring, and that the contents gauge has tool access.

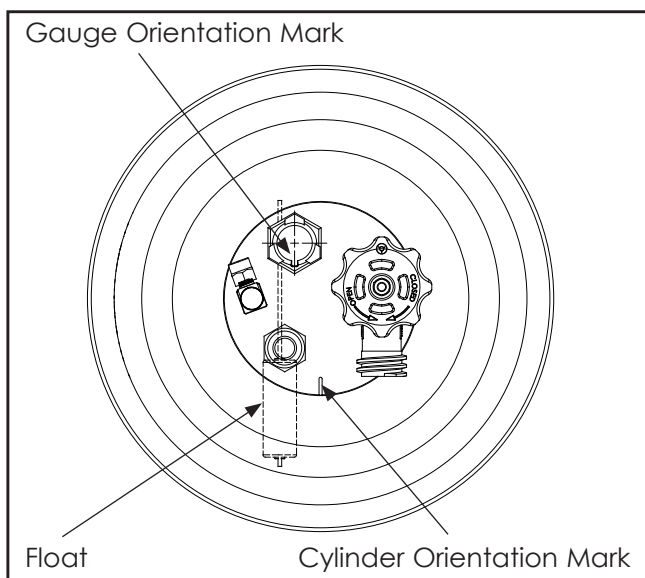

▲ Fig. 7.52.3: Orientation of Gauge

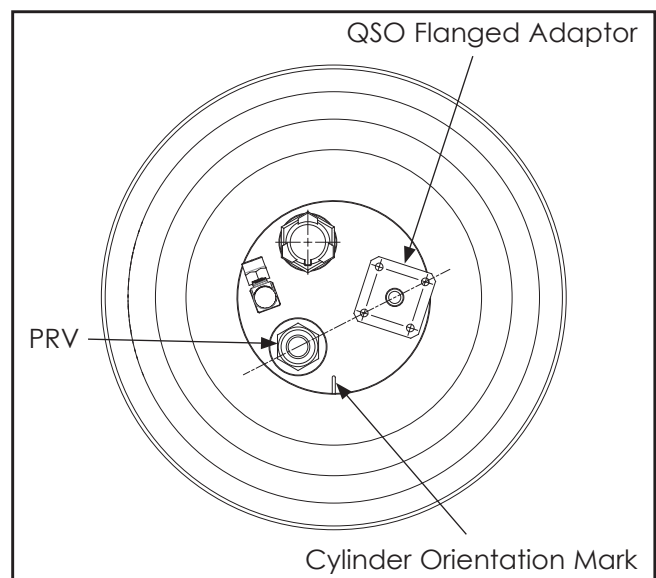

▲ Fig. 7.52.4: Orientation of QSO Flanged Adaptor

7.52.10.7 Overfill Protection Device (OPD)

Part No.	Description	Applicability
CB-2920-0000	Overfill Protection Device	CB2901, CB2902, CB2903

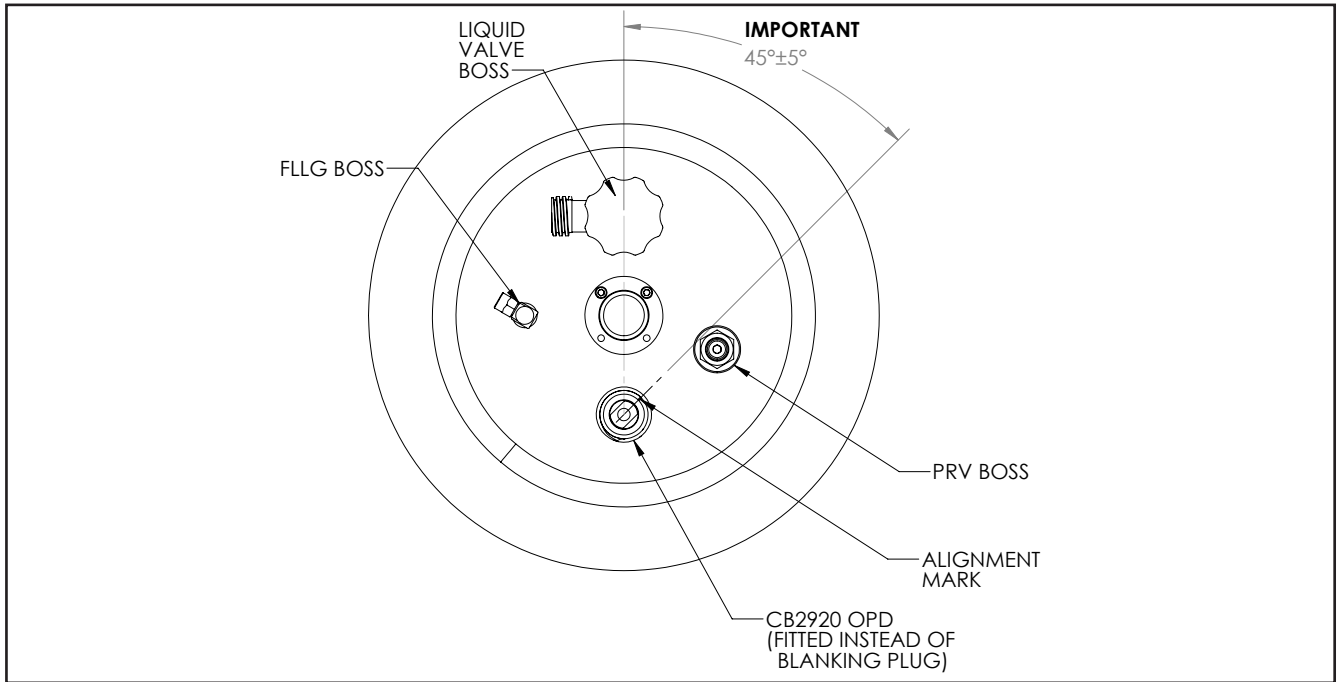

▲ **Fig. 3: OPD Alignment Detail**