

The technical content of this document is approved under the authority of DOA ref. EASA. 21J.140 (C773 Iss. 3)

7.57 STRATUS NEO AND STRATUS NEO MINI BURNERS

7.57.1 General

This supplement shall be inserted in the Maintenance Manual, in Section 7: 'Supplements' with the revisions record sheet amended accordingly.

Information contained herein supplements, or in the case of conflict, supersedes that contained in the basic Maintenance Manual. For Limitations, Procedures, and Performance Data not contained in this supplement, consult the basic Hot Air Balloon Maintenance Manual.

All procedures and parts referenced are applicable to both the Stratus Neo and Stratus Neo Mini Burners.

Issue 4 of this supplement consists of fourteen pages.

7.57.2 ENVELOPE REPAIRS

No Change

7.57.3 BASKET REPAIRS

No change.

7.57.4 FUEL SYSTEM REPAIRS

7.57.4.1 Regular Maintenance

7.57.4.1.1 Lubrication of Main Blast, Toggle Whisper, and Pilot Light Valves

If the control valves become stiff to operate the valve stem seals may require lubrication. For routine maintenance this can best be achieved by spraying a little silicone lubricant onto the exposed part of the stem for the Main Blast, Toggle Whisper, and Pilot Light Valves.

Alternatively apply a light smear of KSP125 grease onto the valve stem where it exits the valve housing. The valve should then be operated several times (with no fuel pressure applied) to work the lubricant down to the seals. For the Main Blast Valve this may require the Burner Handle to be removed. This is done by unscrewing the two hexagon socket bolts visible within the valve housing at each end of the handle.

The Main Blast and Whisper valve stems may also be lubricated via the greasing port in the valve shroud. To do this the greasing port screw should first be removed using a flat blade screwdriver. KSP125 grease can then be injected into the exposed port. The screw should then be refitted and fully tightened.

7.57.4.1.2 Lubrication of Main Blast, Toggle Whisper, and Pilot Light Control Handles

If the control handles become stiff to operate the handle mechanisms may require lubrication. A small amount of KSP125 grease should be applied to the pivots and sliding surfaces. The control should then be operated several times to work the lubricant into the mechanism. For the Main Blast control removal of the Burner Handle may be necessary, as described in 7.57.4.1.1.

7.57.4.1.3 Rotary Whisper Valve, Lubrication and Adjustment

For lubrication or adjustment of the Rotary Whisper Valve, removal of the control handle/knob is required. This is done with the control handle in the closed position, by unscrewing the hexagon socket bolt (1) located within the blue handle (2).

The handle and knob (3) can then be lifted away to reveal the valve mechanism. A small amount of light oil or KSP125 grease should be applied to the stem and sliding surfaces. The control should then be operated several times to work the lubricant into the mechanism and seals.

If the Rotary Whisper Valve fails to shut-off it requires adjustment as follows:-

1. With the control knob removed, turn the valve mechanism until the end stop at the low end of the ramps on the blue housing is in contact.
2. Using a hexagon key unscrew the grub screw (4) that retains the valve cam (5) to the adjuster (6) and valve stem (7). Making sure the other parts do not rotate, remove the grub screw.
3. Using the slot on the top face of the adjuster, carefully rotate it by $\frac{1}{4}$ of a turn clockwise while holding the cam against the end stop. Re-fit the grub screw using the same slot in the cam as before.
4. Rotate the valve mechanism and check the amount of free movement before the ramp begins to lift the valve stem. The free movement should be approximately 10° from the end stop.
5. If the ramp action begins to engage at less than 10° , repeat stage 3 until the correct angle is achieved.
6. With the adjustment set, ensure that the grub screw is centred so that neither end protrudes outside of the cam outer diameter.

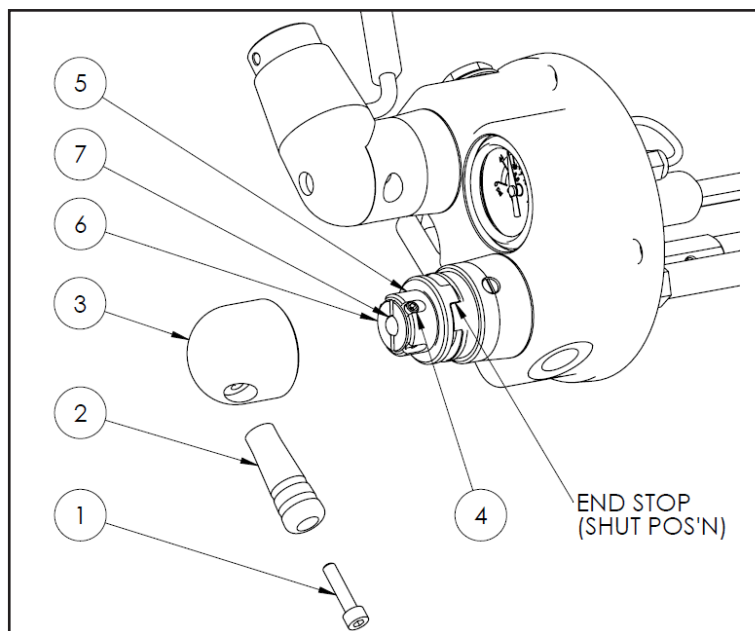

▲ Stratus Neo Rotary Whisper Valve

After lubrication and/or adjustment refit the knob and handle and secure with the hexagon socket bolt, fully tightened.

7.57.4.2 LIQUID PILOT LIGHT

7.57.4.2.1 General Description

The Liquid Pilot Light consists of a flame tube mounted on a pressure regulator/vaporiser, which is in turn mounted on top of the manifold valve block. The regulator automatically maintains a constant pilot light flame size regardless of fuel pressure and altitude. The system contains an integral filter to remove any particles from the fuel supply.

Contamination of the Liquid Pilot Light system usually manifests itself as a progressive reduction in pilot flame size. If the flame size decreases, then the regulator and jet should be dismantled and cleaned before the next flight.

7.57.4.2.2 Regulator Assembly, Stripping and Cleaning

To clean the regulator assembly and jet proceed as follows:-

1. Unscrew the regulator housing (1) together with the pilot light flame tube (2), using a spanner. This will either separate the regulator upper housing (1) from the lower fitting (3) or extract the complete regulator assembly from the valve block.

CAUTION: Take care not to damage the igniter electrode during removal of the regulator assembly.

2. Unscrew the regulator upper housing from its lower fitting (if necessary), and carefully remove the spring (4) and piston assembly (5).

WARNING: Do not tightly clamp the regulator upper housing (1) in a bench vice or other tool as this can distort the part causing incorrect operation.

3. Unscrew the flame tube (2) from the regulator upper housing to reveal the pilot light jet (6).
4. Unscrew the jet to reveal the filter (7). If either of these items appears to be blocked or contaminated then they should be replaced with new parts, or thoroughly cleaned using a hydrocarbon solvent before being refitted.
5. Inspect the inside of the regulator upper housing and the piston assembly for contamination, and carefully wipe clean using a soft lint-free cloth if necessary.
6. Check that the rubber seal (9) on the end of the piston and the rubber O-ring (8) are secure and in good condition. If either is damaged they must be replaced.

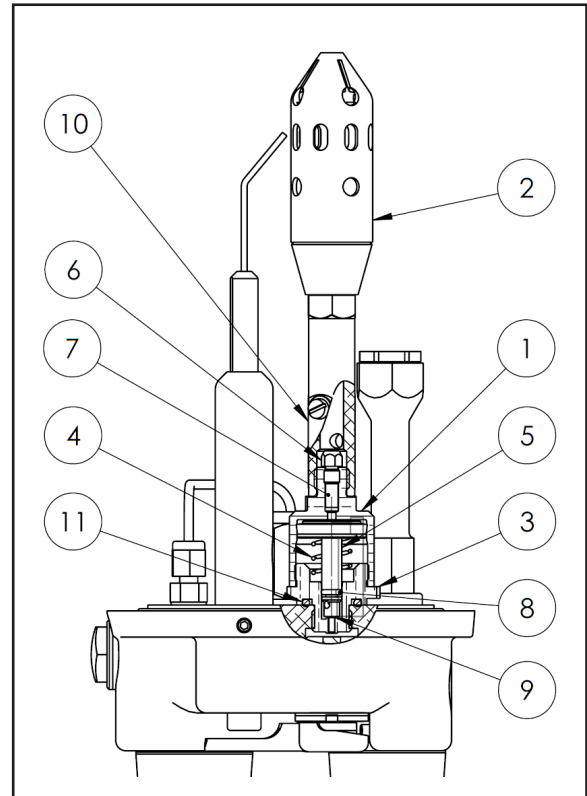

▲ Stratus Neo Liquid Pilot Light

7. When all parts have been checked and cleaned the pilot light system can be reassembled. Apply a very thin smear of KSP125 grease to the piston sealing ring (white) and O-ring. Carefully refit the piston assembly into the regulator upper housing, taking care not to damage the sealing ring on the screw thread inside the housing.
8. Refit the regulator spring (4) and screw the two parts of the regulator together.
9. Refit the pilot light flame tube onto the regulator ensuring that the parts are tightly screwed together, and that the air regulator (10) is covering one of the two intake holes.
10. Refit the pilot light assembly into the valve block, ensuring that the static sealing ring (11) is correctly in position.
11. Tighten the pilot light flame cup (2) until it is possible to set the tip of the igniter electrode such that a spark of 4-6 mm jumps to the edge of one of the slotted holes in the flame cup.
12. Test the pilot light system when completed, checking for external leaks, reliable ignition from the piezo igniter and normal flame size and appearance.

7.57.4.4 Replacement of the Piezo Igniter

In the event of failure of the piezo igniter the whole igniter assembly should be removed from the burner for repair.

1. Move the pilot light valve handle (1) to the 'on' position to reveal the piezo igniter housing.
2. Using a 2.5 mm hexagon key loosen the grub screw (2) in the side of the manifold valve block.
3. Extract the igniter assembly (3) out through the base of the valve block.
4. With the assembly removed from the burner, unscrew the piezo push-button unit (4) to remove all the internal parts of the assembly.
5. Replace any defective items and carefully re-insert the parts into the housing, ensuring that the flats on the electrode correctly locate within the slotted hole of the housing.
6. Tighten the piezo push-button unit into the housing.
7. Check the O-ring (5) is in good condition and lightly smear with KSP125 grease. Re-fit the assembly into the valve block, and push in fully.

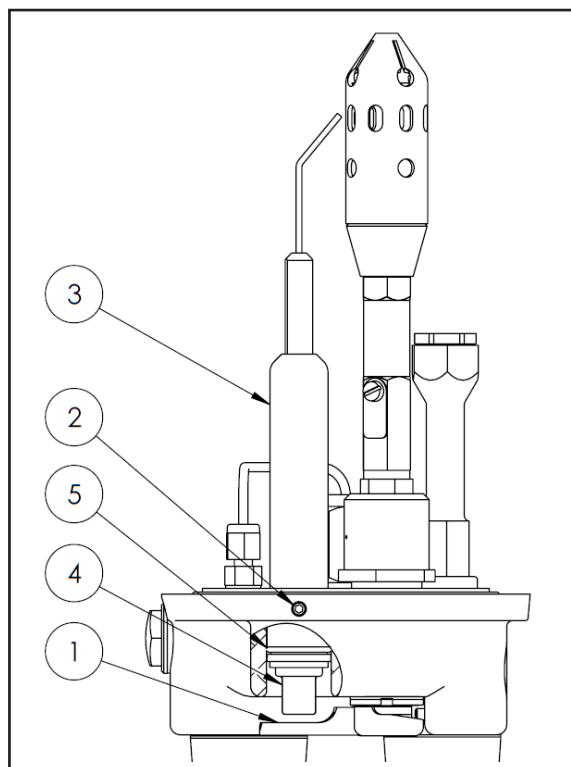

▲ Stratus Neo Piezo Igniter

8. Adjust the position of the electrode tip to ensure the spark gap is 4-6 mm and the spark jumps to the edge of one of the slotted holes of the flame cup.
9. Tighten the grub screw loosened at stage 2 to securely hold the igniter assembly within the manifold block.

7.57.4.5 STRATUS NEO AND STRATUS NEO MINI MAIN BURNER JETS

Burner jets may be removed for cleaning, inspection or replacement using a socket spanner. The copper washer underneath the jet must be replaced each time the jet is removed. The jets should be tightened to a maximum of 17 Nm (12 lb.ft).

Regular inspection will reveal any loose or missing jets. Any jets which are loose should be removed and refitted using a new copper washer.

7.57.4.6 CROSSFLOW VALVE (TRIPLE AND QUAD BURNERS ONLY)

Minor leaks from the handle of the valve may be cured by tightening the stem:-

1. Remove and discard the 'Nyloc' nut that retains the handle.
2. Apply Loctite 270 Studlock or equivalent to the threads of the spindle.
3. Using a new 'Nyloc' nut, tighten the nut onto the spindle, checking the ease of rotation of the handle. The handle should move easily, but with noticeable friction. Over-tightening the nut will make the valve stiff to operate and will cause premature wear of the seals.

Other faults will require replacement of the valve.

7.57.4.12 BURNER VALVE SEAL REPLACEMENT

7.57.4.12.1 OVERHAUL OF THE MAIN BLAST VALVE

7.57.4.12.1.1 Remove the Burner Handle from the Burner

Remove the Burner Handle by removing the two M5 cap screws (1) at each end of the handle assembly. (4.0mm A/F hexagon key tool req'd)

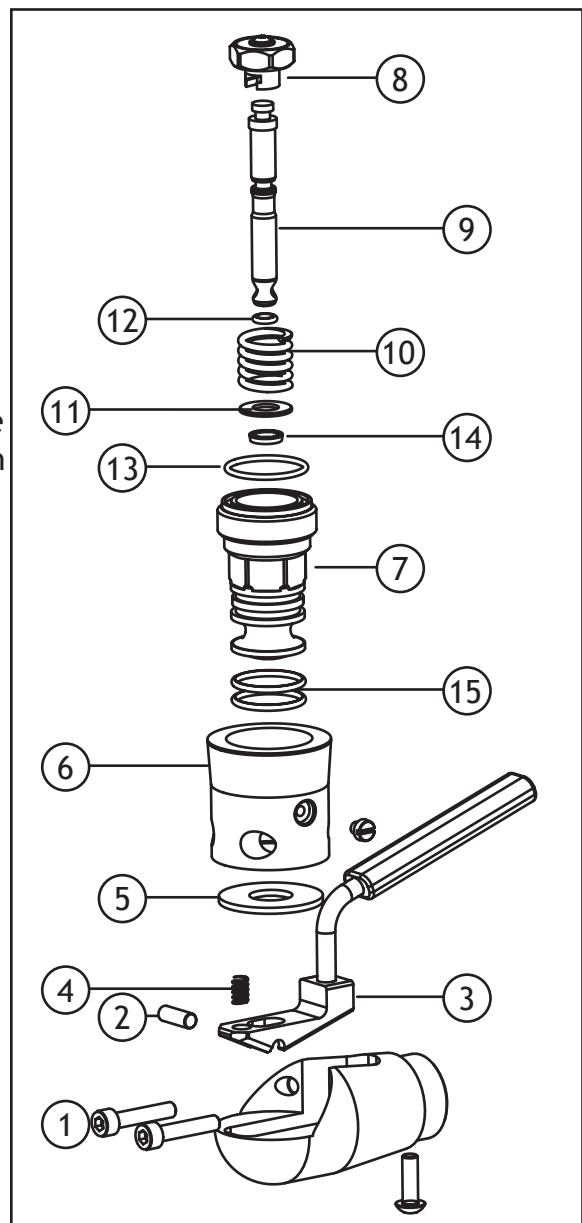

▲ Main Blast Valve

7.57.4.12.1.2 Remove the Main Blast Valve Trigger Assembly

Using a suitable implement, push the Pivot Pin (2) out of the Main Blast Trigger (3). Take care to catch the small spring (4) as the Trigger assembly is removed. Remove and retain the Pivot Pin, Trigger and Trigger Spring.

7.57.4.12.1.3 Remove the Main Blast Valve from the Manifold Block Assembly

Lift off the Wear Pad (5) and Handle Shroud (6) to reveal the Main Blast Valve Housing (7).

Restrain the Burner Assembly to allow loosening of the valve housing. Using a 22 mm (7/8") A/F Spanner loosen the Valve Housing. (This may require a soft faced mallet to tap the spanner).

The Main Blast Valve assembly can now be unscrewed and removed from the manifold block.

7.57.4.12.1.4 Replacement of the Main Blast Valve Shutter Assembly

To fit a new Shutter Assembly (8) pull the Shutter/Stem a few millimetres down within the housing such that the T-slot connection between the two parts is clear of the valve spring. The old Shutter Assembly can then be slipped off the end of the Stem (9) and the new Shutter Assembly fitted in its place.

7.57.4.12.1.5 Replacement of Main Blast Valve Stem Seal

Remove the valve stem, spring (10) and stainless steel washer (11) from the valve housing. Remove and discard the small stem 'O'-ring (12).

Clean the stem and inspect the stem for damage. If the stem is damaged, it must be replaced.

Lubricate the stem and 'O'-ring using KSP grease and carefully fit the new 'O'-ring onto the stem.

7.57.4.12.1.6 Overhaul of Blast Valve Housing

Remove and discard the 'O'-ring face seal (13) and PTFE spring seal (14) from the upper face of the valve housing, and the two grease groove 'O'-rings (15) from the outer diameter.

Clean the Valve Housing. Inspect the Housing for excessive wear or scoring of the valve bore, if it is damaged it will need to be replaced.

Lightly lubricate and assemble the replacement PTFE spring seal and 'O'-rings with KSP grease.

IMPORTANT: Care must be taken to avoid damage to the new PTFE spring seal as it is fitted into the location recess. Light, even pressure should be applied across the whole diameter of the seal. Ensure the PTFE spring seal has the open side (with the metal spring visible) showing when installed. Inspect the installed seal location for any slivers of white plastic or uneven appearance of the white edges either side of the internal spring. If either of these conditions is observed the seal has been damaged during installation and will need to be replaced.

7.57.4.12.1.7 Reassembly of Main Blast Valve Assembly

Position the stainless steel washer over the PTFE spring seal within the Valve Housing.

Position the Valve Spring on top of the stainless steel washer.

Ensure the Valve Stem is lubricated with KSP grease before insertion. Carefully insert the Valve Stem/Shutter assembly into the valve housing, taking care not to damage the seals.

7.57.4.12.1.8 Reassembly of Main Blast Valve into the Manifold Block Assembly

Ensure the port of the Manifold Block is clean and free of debris.

Check the 'O'-ring (13) is in position on the end of the Valve Housing. A small amount of KSP 125 grease may be used to hold it within the face seal groove if required.

Restrain the Burner Assembly to allow tightening of the valve housing.

Screw the Main Blast Valve into the Manifold Block and tighten to a torque of 90 Nm (66 lb ft).

7.57.4.12.1.9 Check of Blast Valve Trigger Assembly

Inspect the Blast Valve Trigger assembly, checking that the Red handle trim is secure. If it is loose, then apply some thread locking compound to the male thread and refit the handle trim, screw down tightly until the correct position is achieved.

7.57.4.12.1.10 Reassembly of Main Blast Valve Trigger

Refit the Handle Shroud (6) and Wear Pad (5), refit the Blast Trigger Spring (4).

Apply a small amount of KSP grease to the Pivot Pin (2). Refit the Blast Trigger Handle and Pivot Pin, ensuring the Trigger Spring locates in the pocket in the face of the Trigger.

7.57.4.12.1.11 Refit the Burner Handle

Refit the Burner Handle and secure using the two M5 Cap Head Screws at each end. Ensure the screws tighten down fully so that both heads are equally recessed within the Handle Shroud.

7.57.4.12.2 OVERHAUL OF THE WHISPER VALVE

7.57.4.12.2.1.1 Remove the Whisper Valve Toggle Handle (optional handle type)

Using a pair of Circlip Pliers carefully remove the Circlip (1) from the handle pivot pin (2).

Press the Pivot Pin out of the Toggle Handle (3). Remove and retain the Pivot Pin, Handle and Wear Pad (4).

Using a 19 mm (3/4") A/F hexagon socket loosen the Ring Nut (5). Unscrew and remove the Ring Nut and the Whisper Valve Shroud (6). Ensure the steel dowel pin (7) remains in the base of the Shroud.

7.57.4.12.2.1.2 Remove the Whisper Valve Rotary Handle (optional handle type)

Remove the M5 Cap Screw, Handle, Knob, Grub Screw, Adjuster, Valve Cam and Ramp Liner using the technique of section 7.57.4.1.3. Retain all the parts for re-fitting.

NOTE: The Valve Cam is a handed component and it should be noted whether it is from the Left Hand or Right Hand valve.

Using a 19 mm (3/4") A/F hexagon socket loosen the Ring Nut. Unscrew and remove the Ring Nut and the Whisper Valve Shroud. Ensure the steel dowel pin remains in the base of the Shroud.

NOTE: The Rotary Whisper Valve Shroud is a handed component and it should be noted whether it is from the Left Hand or Right Hand valve.

7.57.4.12.2.2 Remove the Whisper Valve from the Manifold Block Assembly

Restrain the Burner Assembly to allow loosening of the valve housing. (8)

Using a 22 mm (7/8") A/F Spanner loosen the Valve Housing. (This may require a soft faced mallet to tap the spanner).

The Whisper valve assembly can now be unscrewed and removed from the manifold block.

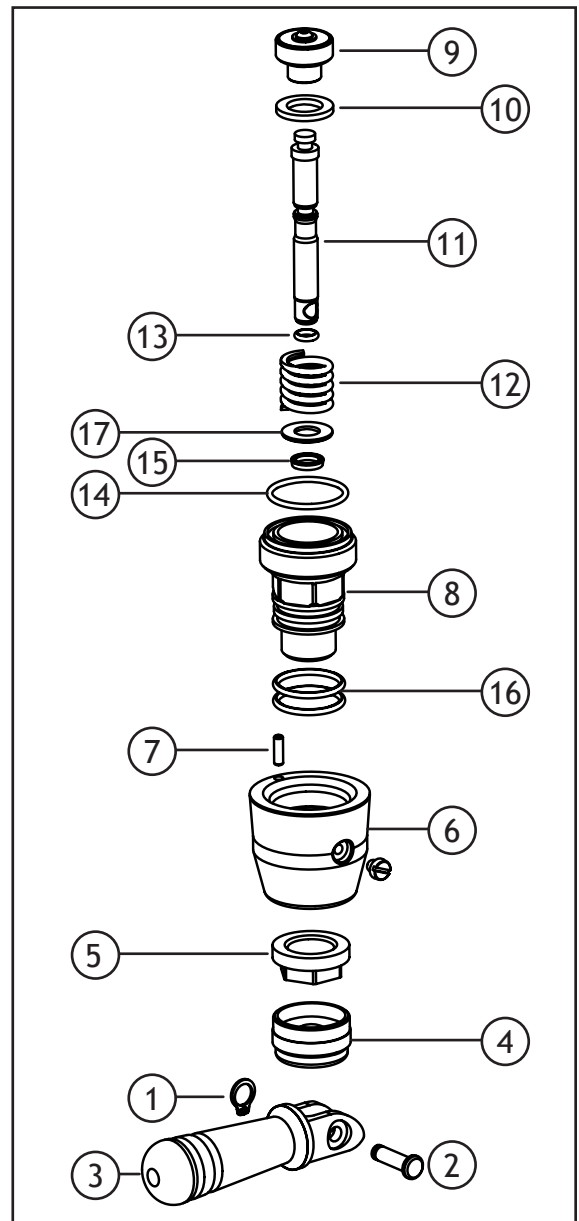

▲ Whisper Valve

7.57.4.12.2.3 Replacement of the Whisper Valve Shutter Assembly

To fit a new Shutter Assembly (9) pull the Shutter/Stem a few millimetres down within the housing such that the T-slot connection between the two parts is clear of the valve spring. The old Shutter Assembly and Slip Washer (10) can then be slipped off the end of the Stem (11) and the new Shutter Assembly and Washer fitted in its place. The Shutter, Washer and Stem should then be pushed back into the housing until the back face of the Slip Washer touches the valve spring (12).

7.57.4.12.2.4 Replacement of Whisper Valve Stem Seal

Remove the valve stem, spring and stainless steel washer (17) from the valve housing. Remove and discard the small stem 'O'-ring. (13)

Clean the stem and inspect the stem for damage. If the stem is damaged, it must be replaced.

Lubricate the stem and 'O'-ring using KSP grease and carefully fit the new 'O'-ring onto the stem.

7.57.4.12.2.5 Overhaul of Whisper Valve Housing

Remove and discard the 'O'-ring face seal (14) and PTFE spring seal (15) from the upper face of the valve housing, and the two grease groove 'O'-rings (16) from the outer diameter.

Clean the Valve Housing. Inspect the Housing for excessive wear or scoring of the valve bore, if it is damaged it will need to be replaced.

Lightly lubricate and assemble the replacement PTFE spring seal and 'O'-rings with KSP grease.

IMPORTANT: Care must be taken to avoid damage to the new PTFE spring seal as it is fitted into the location recess. Light, even pressure should be applied across the whole diameter of the seal. Ensure the PTFE spring seal has the open side (with the metal spring visible) showing when installed. Inspect the installed seal location for any slivers of white plastic or uneven appearance of the white edges either side of the internal spring. If either of these conditions is observed the seal has been damaged during installation and will need to be replaced.

7.57.4.12.2.6 Reassembly of Whisper Valve Assembly

Position the stainless steel washer (17) over the PTFE spring seal within the Valve Housing.

Position the Valve Spring on top of the stainless steel washer.

Ensure the Valve Stem is lubricated with KSP grease before insertion. Carefully insert the Valve Stem/Shutter assembly into the valve housing, taking care not to damage the seals.

7.57.4.12.2.7 Reassembly of Whisper Valve into the Manifold Block Assembly

Ensure the port of the Manifold Block is clean and free of debris.

Check the 'O'-ring (14) is in position on the end of the Valve Housing. A small amount of KSP 125 grease may be used to hold it within the face seal groove if required.

Restrain the Burner Assembly to allow tightening of the valve housing.

Screw the Whisper Valve into the Manifold Block and tighten to a torque of 90 Nm (66 lb ft).

7.57.4.12.2.8.1 Check of Whisper Valve Toggle Handle (optional handle type)

Inspect the Valve Handle and Pivot Pin for excessive wear or other damage. Replace if required.

7.57.4.12.2.8.2 Reassembly of Whisper Valve Toggle Handle (optional handle type)

Refit the Whisper Valve Shroud (6), ensure the steel dowel pin (7) fits into the hole in the face of the Manifold Block. Refit the Ring Nut (5) to retain the Shroud and fully tighten.

Refit the Wear Pad (4) into the end of the Whisper Valve Shroud.

Apply a small amount of KSP grease to the Pivot Pin. Refit the Toggle Handle and Pivot Pin.

Fit the replacement Circlip (1) onto the Pivot Pin (2), taking care to ensure it is fully located into the circlip groove on the pin.

7.57.4.12.2.9 Reassembly of Whisper Valve Rotary Handle (optional handle type)

Refit the Whisper Valve Shroud, ensure it is the correct hand part and that the steel dowel pin fits into the hole in the face of the Manifold Block. Refit the Ring Nut to retain the Shroud and fully tighten.

Refit the Ramp Liner, Valve Cam and Adjuster. Ensure the Valve Cam is the correct hand part.

Carry out the valve adjustment and handle assembly procedure of Section 7.57.4.1.3.

7.57.4.12.3 OVERHAUL OF THE PILOT LIGHT VALVE

7.57.4.12.3.1 Remove the Pilot Light Valve Handle

Using a 2.5 mm A/F hexagon key loosen the M3 Cap Screw (1) which retains the Pilot Valve Handle (2). Remove the Cap Screw, Handle and Knob (3) from the Pilot Light Valve.

7.57.4.12.3.2 Remove the valve actuating Pin

Remove the brass Pin (4) from the hole in the Manifold Block and retain for re-use.

7.57.4.12.3.3 Remove the Pilot Light Valve assembly from the Manifold Block

Using a 19 mm (3/4") hexagon socket unscrew the Pilot Light Valve assembly from the Manifold Block.

CAUTION: The hexagon feature on the Valve Nut (5) is only 3 mm deep so a socket tool without a lead-in chamfer must be used to give fully depth engagement on the hexagon, otherwise damage to the Valve Nut may result.

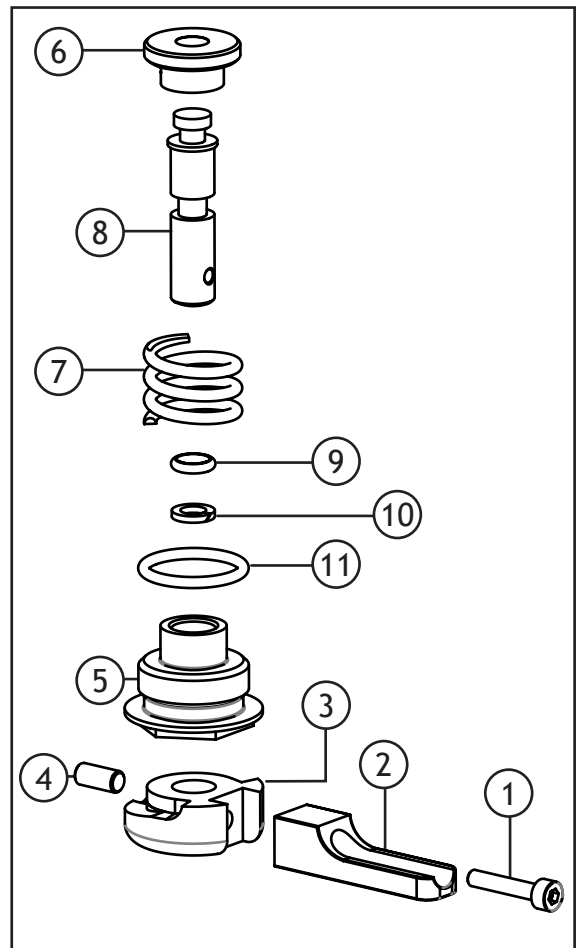

▲ Pilot Light Valve

7.57.4.12.3.4 Replacement of the Pilot Light Valve Shutter Assembly

To fit a new Shutter Assembly (6) pull the Shutter/Stem a few millimetres down within the housing such that the T-slot connection between the two parts is clear of the valve spring. (7) The old Shutter Assembly can then be slipped off the end of the Stem (8) and the new Shutter Assembly fitted in its place. The Shutter and Stem should then be pushed back into the housing until the back face of the Shutter touches the valve spring.

7.57.4.12.3.5 Replacement of Pilot Light Valve Stem Seals

Remove the valve stem and spring from the valve housing. Remove and discard the small stem 'O'-ring (9) and white PTFE split ring (10).

Clean the stem and inspect the stem for damage. If the stem is damaged, it must be replaced.

Lubricate the stem and 'O'-ring using KSP grease and carefully fit the new 'O'-ring into the stem seal groove nearest to the T-slot connection. Fit the new white PTFE split ring next to the 'O'-ring.

7.57.4.12.3.6 Overhaul Pilot Light Valve Nut

Remove and discard the 'O'-ring seal (11) from behind the flange of the Valve Nut (5).

Clean the Valve Nut. Inspect the part for excessive wear or scoring of the valve bore, if it is damaged it will need to be replaced.

Lightly lubricate and assemble the replacement 'O'-ring with KSP grease.

7.57.4.12.3.7 Reassembly of Pilot Light Valve Assembly

Ensure the Valve Stem is lubricated with KSP grease before insertion. Carefully insert the Valve Stem/Shutter assembly through the Spring into the Valve Nut, taking care not to damage the stem seals.

7.57.4.12.3.8 Reassembly of Pilot Light Valve into the Manifold Block Assembly

Ensure the port of the Manifold Block is clean and free of debris.

Check the 'O'-ring (11) is in position under the flange of the Valve Nut (5).

Restrain the Burner Assembly to allow tightening of the valve assembly.

Screw the Pilot Light Valve into the Manifold Block and tighten using a hexagon socket.

CAUTION: The hexagon feature on the Valve Nut is only 3 mm deep so a socket tool without a lead-in chamfer must be used to give fully depth engagement on the hexagon, otherwise damage to the Valve Nut may result.

7.57.4.12.3.9 Reassembly of Pilot Valve Handle

Refit the valve actuating Pin (4) into the hole in the Manifold Block.

With the threaded hole in the Valve Stem (8) positioned in-line with the Pin (4), refit the Valve Knob (3) and Handle (2). Apply a small amount of KSP grease to the ramp feature on the Knob.

Refit the M3 Cap Screw (1) so that it engages the threaded hole in the Valve Stem and fully tighten.

7.57.4.12.4 GROUND TEST TO CONFIRM CORRECT FUNCTIONING

Test fire the burner to confirm correct functioning of the valves, and that there are no internal or external fuel leaks from any position before resuming flight usage.

7.57.5 INSTRUMENT REPAIRS

No change.

7.57.6 MAINTENANCE SCHEDULE

No change.

7.57.8 REPAIR PARTS AND MATERIALS

7.57.8.4.12 Stratus Neo and Stratus Neo Mini Burner

Part Number	Description
CB-0214-0006	Copper Washer (for use with the Main Set)
CB-4142-0000	Main Jet Assembly
CB-4057-0000	Igniter Electrode
CB-8546-0000	Vaporiser Outlet Filter, Liquid Pilot Light
CB-8550-0000	Liquid/Vapour Pilot Light Jet
CB-8624-1000	Liquid Pilot Light Regulator Service Kit
CB-8505-0000	Piezo Igniter Unit
CB-4110-3000	Pilot Light Valve Service Kit
CB-4110-1000	Main Blast Valve Service Kit
CB-4110-2000	Whisper Valve Service Kit
CB-4110-4000	Liquid Pilot Vaporiser Seal Kit
CB-4110-5000	Igniter Assembly Seal Kit
CB-4110-6000	Coil Stem Seal Kit

Intentionally Blank Page